

# Application Aspects of IPv6 Transition

draft-shin-v6ops-application-transition-01.txt

Myung-Ki Shin, Yong-Guen Hong, ETRI

Jun-ichiro Itojun Hagino, IIJ

Pekka Savola, CSC/FUNET

Eva M. Castro, GSYC/URJC

**IETF-57 v6ops Meeting @ Vienna, Austria**

# Why this draft ?

- As IPv6 is deployed, the application developers and the administrators will face several problems
  - clarifies the problems and considerations
  - application transition scenarios (cases)
  - proposes guidelines on developing IP version-independent applications
- One of the charter items of this wg
  - good starting point for this topic

# Changes and comments (00->01)

- Technical (some issues have been clarified)
  - Transition scenarios(cases) and guidelines
  - IP version dependencies in applications
  - Developing IP version-independent applications
    - Some simple working examples are added
- Non-technical
  - Editorial changes
  - Eva was newly joined on the author team
  - Large amount of support from the mailing list for this effort
  - Apps AD's comments
    - Persons from Apps Area will join on the author team (Apps Area Meeting on Mon. 14)

# IPv6 Application transition cases

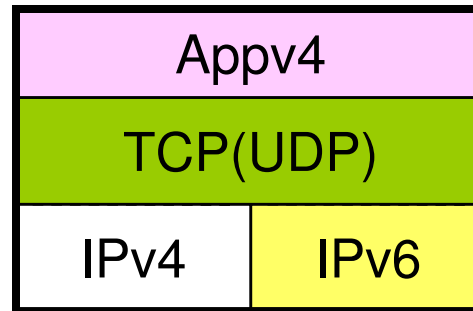
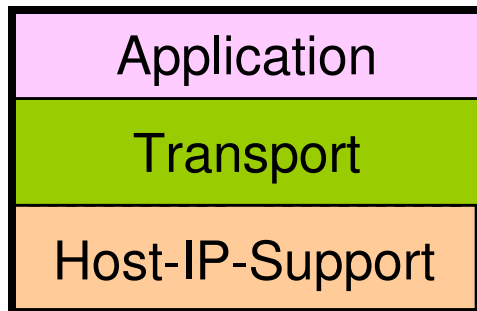

Case 1

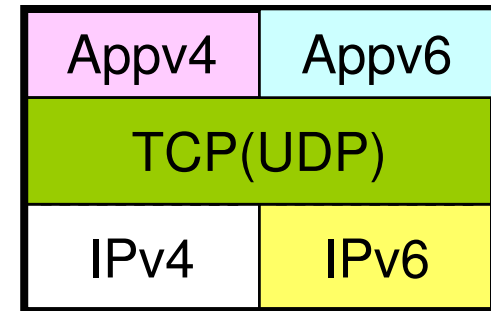

Case 2

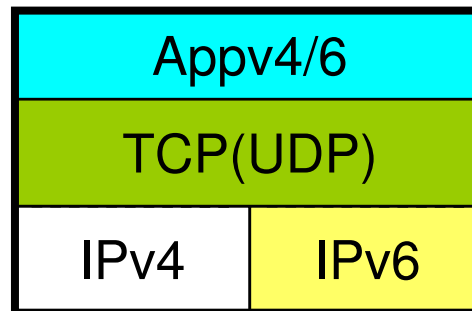

Case 3

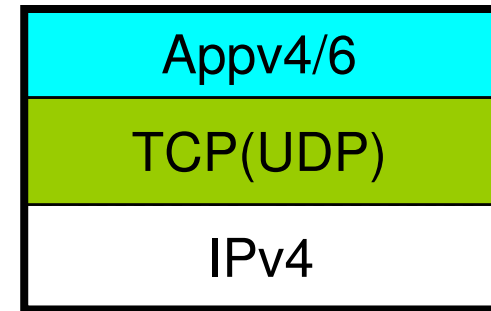

Case 4

# General Problems with IPv6 application transition

- Dual-stack vs. application versions
  - Operating system being dual stack does not mean having both IPv4 and IPv6 applications
- DNS name resolution
  - A client application can not know the version of peer application by only doing a DNS name lookup
- Application selection
  - Users may be confused by their various application versions (IPv4-only, IPv6-only, IPv4/IPv6) because they don't know the version of peer application by DNS query results

# Case 1 & Case 2

- Case 1 : IPv4 applications in a dual-stack node
  - the first priority is to port applications to IPv6
  - In some cases (e.g. no source code is available), existing IPv4 applications can work if the [BIS] or [BIA] mechanism is installed in the node
- Case 2 : IPv6 applications in a dual-stack node
  - The easiest way to port an IPv4 application is to substitute the old IPv4 API references by the IPv6 new ones, one-to-one API mapping
  - This case is undesirable since maintaining two versions of the same source code per application, could be a difficult task

# Case 3 & Case 4

- Case 3 : IPv4/IPv6 applications in a dual stack node
  - Applications should prefer IPv6 if the remote node and application support it. However if IPv6 connections fail, dual applications will automatically try IPv4 ones
- Case 4 : IPv4/IPv6 applications in an IPv4-only node
  - An example is an application that issues a `socket()` command, first trying `AF_INET6` and then `AF_INET`. However, if the kernel does not have IPv6 support, the call will result in an `EPROTONOSUPPORT` or `EAFNOSUPPORT` error. Typically, if errors are encountered, this leads to exiting the socket loop, and `AF_INET` will not even be tried

# Application porting considerations

- IP version dependencies in applications
  - Presentation format for an IP address
    - dotted-decimal string for IPv4 vs. hexadecimal string for IPv6
  - Transport layer API
    - functions to establish communications and to exchange information
  - Name and address resolution
    - conversion functions b/w hostnames and IP addresses
  - Specific IP dependencies
    - IP address selection, application framing, storage of IP addresses

# Developing IP version-independent applications

- In order to allow applications to communicate with other IPv6 nodes, the first priority is to convert the applications supporting both IPv4 and IPv6
  - IP version-independent structures & APIs
- The applications should do iterated jobs for finding the working address out of addresses returned by `getaddrinfo()`
- The applications will have to work properly in IPv4-only nodes (whether IPv6 protocol is completely disabled)

# Open Issues

- **Transition mechanism considerations**
  - Handling NAT-PT(DNS-ALG) address prefix
  - Any other mechanisms ?
- **Security considerations**
  - Handling IPv4 mapped IPv6-addresses
  - ...

# Discussion

# Plan and Apps AD comments